

Connect it Desking L-Set with Pedestal

**Step 1.** Parts for Unit

Stretcher Bar to connect to each O'Leg and to the Bottom of Worksurface for support  
Stretcher can be Fixed Width style or an Adjustable Style, depending on desk size

NOTE: - Your Tops may be different size

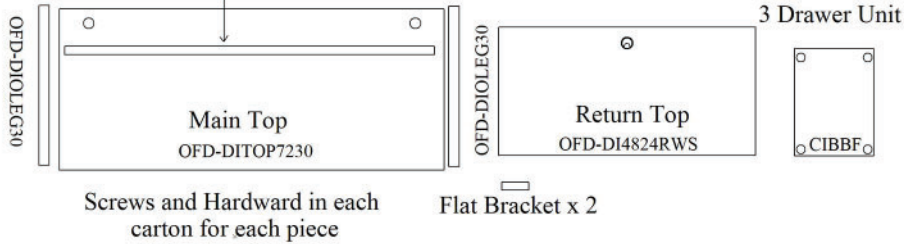

**Step 2.** Connect O=Legs and Stretcher

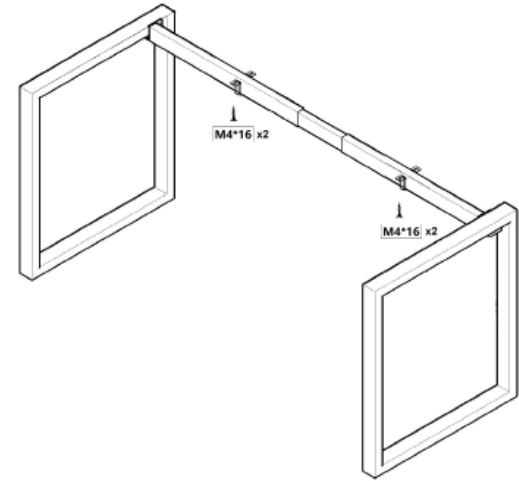

**Step 3.** Lay Top up-side-down on padded floor or blanket as pictured. Use hardware in O'Legs and Stretcher to attach together putting the frame from step 2 on the work-surface

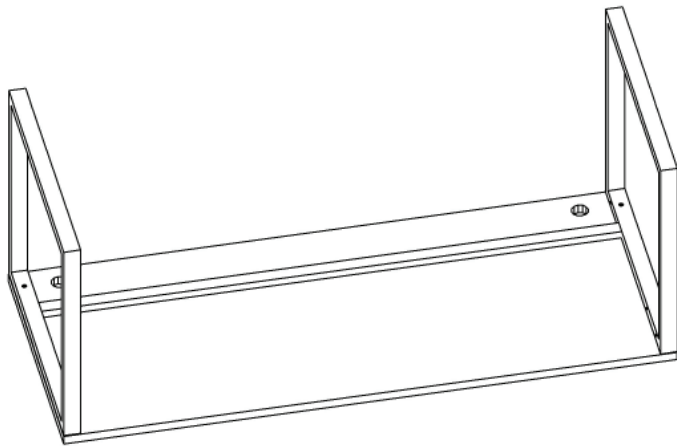

**Step 4.** Stand Desk Up - Return can be assembled to work on the Left or the Right. Choose your preference and install 2 flat brackets (we show RIGHT for illustr-

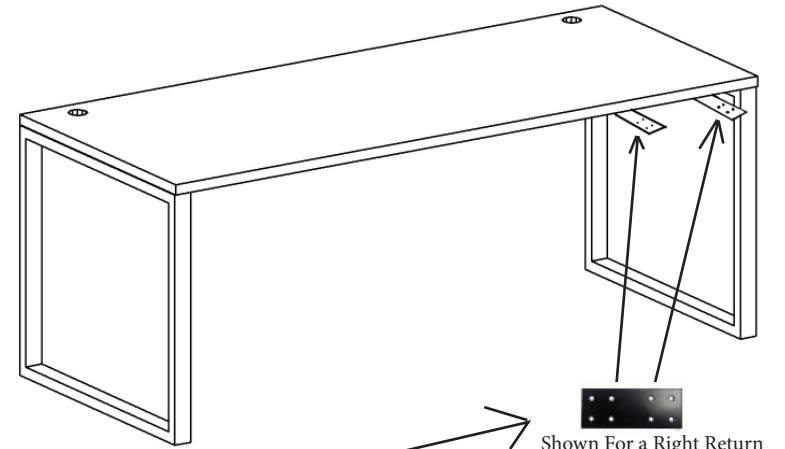

Install 2 flat brackets on the side for your return on the BOTTOM OF THE WORK-SURFACE. The flat brackets need to be about 4-5" from end of desk for one, and about 18" for the second, using 4 bracket screws and aligning the bracket about half under the top.

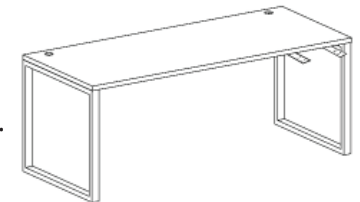

**Step 5.** Remove 3 drawers from the unit to install to the return work-surface. Extend one drawer at a time all the way out, then locate the small tabs on each side of the drawer inside the track - push one of them up and one of them down at the same time and pull out drawer

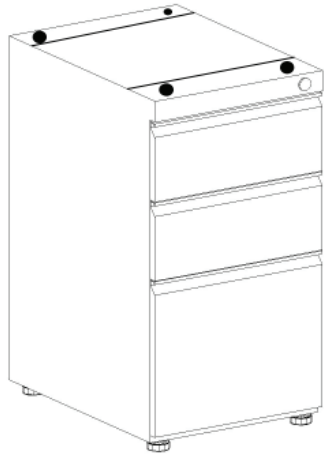

Position Drawer unit with drawers removed as shown. Position the return top on the Flat Brackets and drawer unit and line up edges and position drawer unit to the end of the return and toward the user side.

Once lined up, install the screws in the flat bracket on the return, then inspect alignment, then install the screws through the bottom of the pedestal up into the work-surface to secure drawer unit to the bottom of the return top.

Install drawers back in Pedestal, starting with bottom drawer - align the glide on each side of the drawer to the track and Gently push drawer all the way closed. Make sure the drawer enters the glides straight and will seem a little extra pushing in to get it installed, then test drawer. Do the same for the others

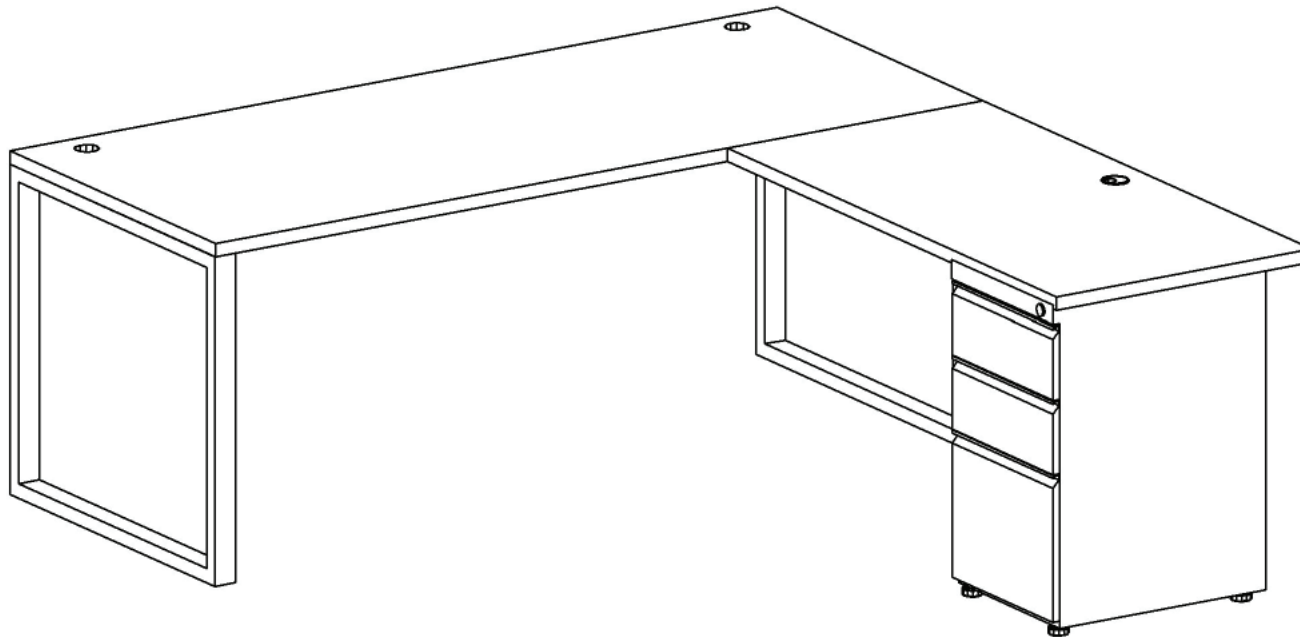

This is an illustration of a Right Return Assembly. The return can be installed on the Left side as well using the same steps except attaching to the left side of the main desk.